

INSTRUCTIONS FOR THE INSTALLATION, OPERATION AND MAINTENANCE OF

FAIRCHILD MODEL 15 PNEUMATIC POSITIVE BIAS RELAY

GENERAL INFORMATION

The Fairchild Model 15 positive bias relay provides an output pressure which is a function of signal pressure plus set bias. Thus output pressure can never be less than the bias pressure which is set into the instrument.

Specifications Model 15

Flow capacity 40 SCFM (68 m³/HR) max
100 psig [7.0 BAR] (700 kPa) supply;
20 psig [1.5 BAR] (150 kPa) setpoint

Exhaust capacity 5 1/2 SCFM (9.4 m³/HR)
downstream pressure 5 psig
[.35 BAR] (35 kPa) above set pressure

Sensitivity 1/4" (.64 cm) W.C.

Effect of supply
pressure variation Less than 0.1 psig
[.007 BAR] (0.7 kPa) for 100 psig
[7.0 BAR] (700 kPa) change

Supply pressure 250 psig [17.0 BAR] (1700 kPa) max

Signal pressure 150 psig [10.0 BAR] (1000 kPa) max

Output pressure 150 psig [10.0 BAR] (1000 kPa) max

Mounting pipe or panel

Ambient temperature limits -40°F to +200°F
(-40°C to 93.3°C)

PRINCIPLES OF OPERATION

Supply air is introduced to the inlet port, exerting pressure against the supply valve and the inner valve assembly balance diaphragm simultaneously. These opposite acting forces keep the supply valve assembly balanced and virtually unaffected by change in supply pressure. When the knob of the Model 15 is adjusted to a specific setpoint, the positive bias spring exerts a force against the top of the signal diaphragm; signal pressure P_s also exerts pressure against the top of the signal diaphragm. The combined force is the result of the sum of P_s acting on the effective diaphragm area and the positive bias spring force, so that $P_o = P_s + K$ where P_o is output pressure, P_s is signal pressure, and K is the spring constant. Thus, the relay output is the sum of signal pressure and the set bias. This force keeps the relief seat against the relief valve. This condition is not achieved until output pressure reaches the desired setpoint. Until then, the downward force opens the supply valve, allowing supply air to be routed to the outlet port. Outlet (downstream) pressure is transmitted through the aspirator tube to the control chamber where it is sensed by the control diaphragm. The increase in pressure on the bottom of the control diaphragm, aided by the supply valve spring force, causes the diaphragm assembly to move upward against the force of signal pressure acting on the top of the signal diaphragm and the positive bias spring force acting on the piston. This force, acting through the pinile, allows the supply valve to throttle, maintaining the output pressure.

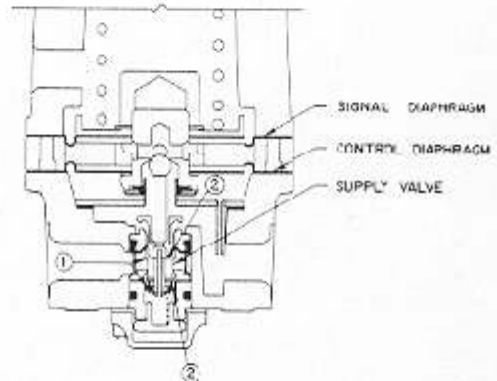

When setpoint is reached, the force acting on the bottom of the control diaphragm is in balance with the force acting on the top of the signal diaphragm. Under these conditions the force (1) due to the supply pressure acting on the underside of the supply valve and force (2) due to supply pressure acting on top of the balance diaphragm are balanced. The force (2) due to downstream pressure acting on top of the supply valve and the force (2) due to downstream pressure acting on the underside of the balance diaphragm are in balance.

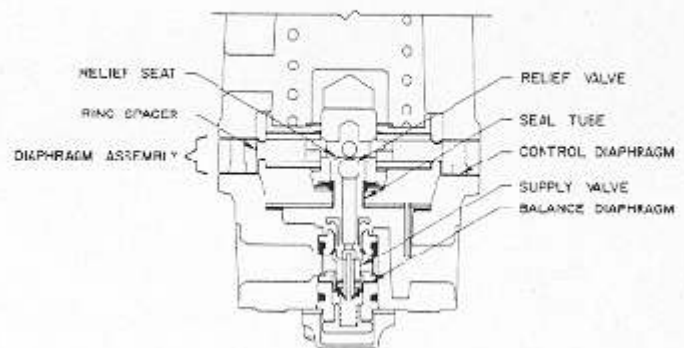
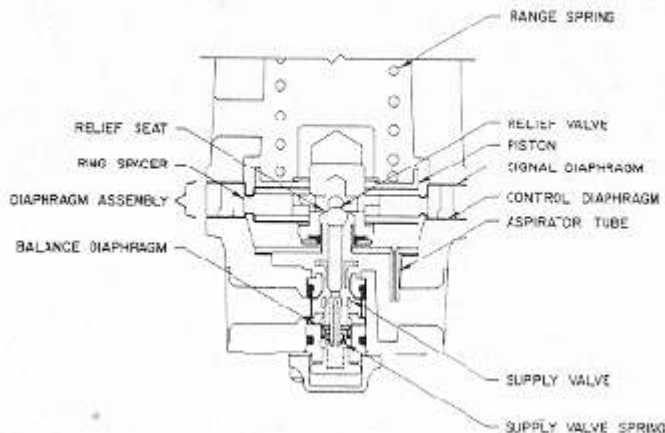

SERVICE KIT INSTALLATION

For Model 15

NOTE: Service kit installation instructions are typical for the Standard Model 15 unit. Partial exploded views are included for the Tamper proof components.

1. Check parts in the EA-12129 service kit against parts marked with an asterisk in the exploded view and the associated table.
2. Mark Bonnet Assembly (3), Ring Spacer (8) and Body (13) so that the relay can be reassembled correctly.
3. Turn Knob Assembly (1) to decrease compression on Spring (6).

For Model 15 Tamper Proof

1. Check parts in the EA-12129 service kit against parts marked with an asterisk in the exploded view and the associated table.
2. Mark Bonnet Assembly (3) and Body (13) so that the relay can be reassembled correctly.
3. Remove Cap Nut (2A) and turn Adjusting Screw (2B) counter clockwise to release compression on Range Spring.

For All Model 15 Relays

4. Remove Six Screws (4) holding Bonnet (3) to Body (13). Lift Bonnet (3) from Body (13) and set aside.
5. Remove Spring Seat (5) and Spring (6) and set aside.
6. Remove Diaphragm Assembly (9) from Ring Spacer (8) and Discard. Secure Diaphragm Assembly (9) from service kit and sandwich over Ring Spacer (8) making sure that six holes in Diaphragm Assembly (9) are aligned with six holes in Ring Spacer (8).
7. Remove Two Screws (18) holding Cap (17) and Spacer (16) to Body (13).

8. Remove Four Screws (10) holding Seal Plate Assembly (11) to Body (13) and remove Seal Plate Assembly (11).
9. Using a soft hammer, tap out Inner Valve Assembly (15), Screen (15A) and Seat Assembly (14) and discard.
10. Remove Gasket (12) from Body (13) and discard.
11. Place Gasket (12) from service kit into well of Body (13) making sure that the four insets in Gasket (12) are aligned with holes in Body (13).
12. Place Seal Plate Assembly (11) in body (13) with aspirator tube extending into the space adjacent to the OUT port.
13. Using four Screws (10), fasten Seal Plate Assembly (11) to Body (13).
14. Secure Seat Assembly (14) from service kit and place, brass end first into bottom well of Body (13). Tap into place using a wooden dowel.
15. Secure Inner Valve Assembly (15) from service kit and place into Body (13). Place Plate (16) and Cap (17) over Inner Valve Assembly (15) and secure with two screws (18).
16. Place Diaphragm Assembly (9) over Body (13) making sure that marks made in step 2 coincide.
17. Place Spring (16) over Hexagonal Nut (7) in Diaphragm Assembly (9). Place Spring Seat (5) over Spring (6).
18. Place Bonnet Assembly (3) over Diaphragm (9) using marks in step 2 and make sure that six holes in Bonnet Assembly (3) are aligned with six holes in Diaphragm Assembly (9).
19. Using six Screws (4), fasten Bonnet Assembly (9) to Body (13).
20. Reinstall the relay in accord with instructions in the IOM and follow instructions in the operators section for placing the relay back in the service.

OPTIONS

	STD	T	E	A	J	U
Knob Assembly	EB-4124-1					
Nut	N/A	EB-1120	N/A	N/A	N/A	N/A
Cap Nut	N/A	EB-7057-2	N/A	N/A	N/A	N/A
Adjusting Screw	N/A	EB-8159-16	N/A	N/A	N/A	N/A
Spacer Ring	EB-7001		EB-8145-9			
Inner Valve Assembly	EB-15075-1	EB-15075-1	EB-15075-1	EB-15809-1	EB-15809-1	EB-15075-1
Diaphragm Assembly	EB-16084-1	EB-16084-1	EB-16084-1	EB-16395-1	EB-16140-1	EB-16084-1
Bonnet Assembly	EB-1895-1	EB-1895-1	EB-1895-1	EB-1895-1	EB-1895-1	EB-1895-2
Seat Assembly	EB-15074-1	EB-15074-1	EB-15074-1	EB-15351-1	EB-15348-1	EB-15074-1

OPTIONS

	EU'	JU'	AU'
Tapped Exhaust Ring	EB-8145-14		
Inner Valve Assembly	EB-15075-1	EB-15809-1	EB-15809-1
Diaphragm Assembly	FR-16084-1	EB-16140-1	EB-16395-1
Seat Assembly	EB-15074-1	EB-15348-1	EB-15351-1

Index.	Part No.	Description
1	EB-4124-1	Knob Assembly
2	EB-1120	Nut
2 A	EB-7057-2	Cap Nut
2 B	EB-8159-15	Adjusting Screw
3	EB-1895-1	Bonnet Assembly
4	EB-1032-20	Screw
5	EB-6058	Spring Seat
6	EB-6060-*	Spring
7	EB-8043-1	Nut
8	EB-7001	Ring Spacer
*9	EB-15084-1	Diaphragm Assembly
10	EB-1032-5	Screw
11	EB-7036	Seal Plate Assembly
*12	EB-6053	Seal Plate Gasket
13	See Table	Body
*14	EB-15074-1	Seat Assembly
*15	EB-15075-1	Inner Valve Assembly
*15 A	EB-6017	Screen
16	EB-6027	Plate
17	EB-7136	Cap
18	EB-1032-6	Screw

*EA-12129 Service Kit Components

OPTIONS

T — Tamper Proof
 E — Tapped Exhaust
 A — Silicone Parts
 J — Viton Parts
 U — British Standard Pipe Thread
 TU, JU, AU — Combination of Above

Port	Body
1/2 NPT	EB-14745-8
3/8 NPT	EB-14745-9
1/4 BSPT	EB-14745-12
3/8 BSPT	EB-14745-13
1/4 BSPP	EB-14745-17
3/8 BSPP	EB-14745-18

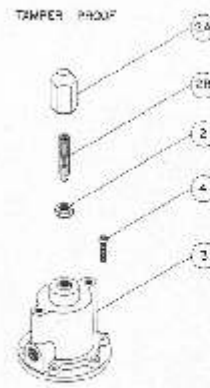

WOOD. 15

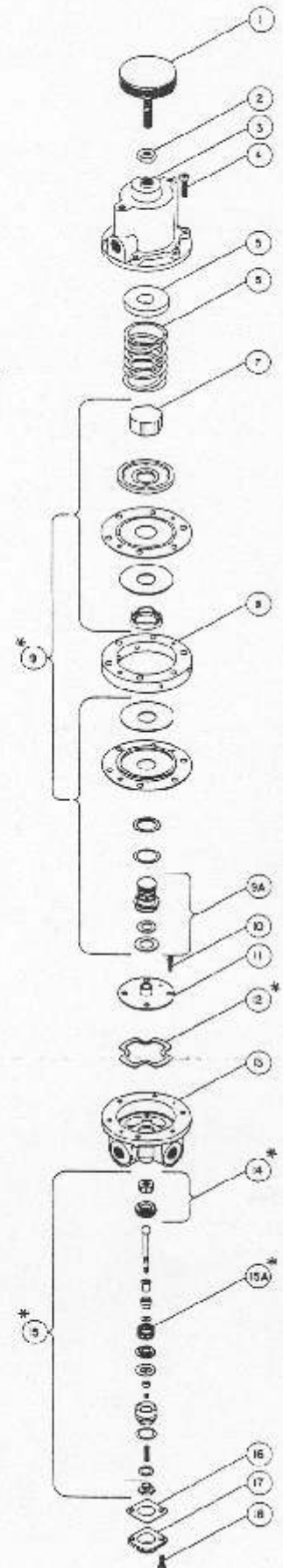

TROUBLE SHOOTING

PROBLEM	CHECK
Leakage	Body screw tightness Diaphragm
High Bleed	Relief pintle and relief seat For damage or contamination
Difficult to Adjust	Adjusting screw and ball Seal ring lubrication

REPAIR PARTS LIST

A service Kit EA-12129 is available for Model 15 maintenance.
For J option Service Kit is 16464-1
For A option service Kit is 16465-1

LEGAL NOTICE:

The information set forth in the foregoing Installation, Operation and Maintenance Instructions shall not be modified or amended in any respect without prior written consent of Fairchild Industrial Products Company. In addition, the information set forth herein shall be furnished with each product sold incorporating Fairchild's unit as



www.fairchildproducts.com



ISO 9001:2000
FM NO. 25571

IS- 30000015
Litho in USA
Rev. H 01/97

P.S.I. Supplies Pty Ltd trading as



For sales information contact:

www.psifluidpower.com.au

sales@psifluidpower.com.au

Ph: +61 (0) 3 9720 5577